

VACUUM LOADERS

TVL SERIES

- **Micro PLC based Controller**
- **Throughput of 50 to 1000 LB / HR**
- **5 Models to choose from:**
 - TVL-1 : non-proportioning
 - TVL-3 : non-proportioning
 - TVL-5 : non-proportioning
 - TVL-2 : proportioning
 - TVL-4 : proportioning

**The Best Choice for
Your Bottom Line**

**... not to mention your
material loading needs!**

TempTek TVL Series Vacuum Loaders

are engineered and built to provide years of reliable service. The modular design allows easy access to maintenance points and quick cleanout for material changeover. They are ideally suited for virgin and/or regrind material.

- Provides 50 to 1000 lb/hr thru-put rate with reliable energy efficient motors.
- Operation is guaranteed with accumulator tank assures stable source of compressed air for filter blowback.
- Less maintenance with polyester filter to trap fines and aluminum support structure.
- Complete and effective filter cleaning with compressed air blowback after every loading cycle.
- Easy "no tool" access via the stainless steel band clamp with safety latch.
- Long service life with the heavy duty stainless steel construction.
- Reliable vacuum is maintained with custom molded neoprene gasket at dump throat and between modular sections.
- Material is always present and ready to load with the low-level switch located at discharge gate (micro magnetic switch available as an option).
- Precise metering of material is ensured with counter balanced discharge gate that automatically closes after evacuation.
- Loading speed is ensured with the tangential inlet that minimizes material degradation.



TVL-5 shown mounted on hopper.

Micro PLC Based Control Instrument

- Complete programming and monitoring capabilities
- Pre-set material proportions and layering of conveyed material
- Can be remotely located at operator level.



The Solid State Temperature control Instrument is standard on all models of TVL Series Vacuum Loaders.

PRICE & PERFORMANCE... for the LONG TERM

525 East Stop 18 Road Greenwood, IN 46142 317-887-6352 fax: 317-881-1277 web site: www.TempTek.com email: sales@TempTek.com

www.aoksupplies.com

TEMPTEK®

since 1989

SPECIFICATIONS

'TVL' SERIES SPECIFICATIONS

MODEL #	TVL-1 ¹	TVL-3 ¹	TVL-5 ¹	TVL-2 ²	TVL-4 ²
VOLUME (cu. ft.)	1.0	1/3	1/8	1.0	1/3
RESIN CAPACITY (lbs)	35	12	4.4	35	12
DISCHARGE DIAMETER	5"	2"	2"	5"	2"
TOTAL LOAD CYCLES (sec.)	0-999	0-999	0-999	0-999	0-999
DUMP CYCLE (sec.)	0-999	0-999	0-999	0-999	0-999
RATIO CYCLE (sec.)	n/a	n/a	n/a	0-999	0-999
COMPRESSED AIR VOLUME (CFM)	.2	.2	.2	.2	.2
AMPS @ 115V	13	13	8	13	13
DIMENSION A	37.6"	28.0"	21.0"	37.6"	28.0"
DIMENSION B	28.9"	21.6"	15.4"	28.9"	21.6"
DIMENSION C	17.4"	10.7"	5.1"	16.4"	10.4"
DIMENSION D	16.0"	10.0"	6.0"	16.0"	10.0"
DIMENSION E	6/13.0"	4/6.9"	4/6.9"	6/13.0"	4/6.9"
SHIPPING WEIGHT	80 lbs	60 lbs	50 lbs	115 lbs	75 lbs

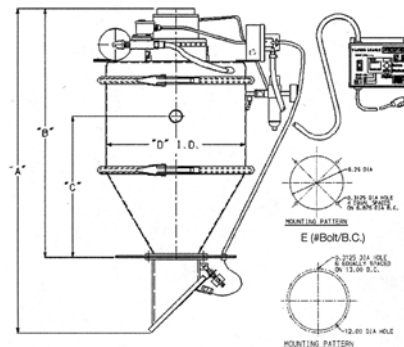

Notes: 1. Non-proportioning loader. 2. Proportioning loader.

GENERAL SPECIFICATIONS - ALL MODELS

VOLTAGE: 115v / 1ph / 50-60Hz

220v / 1ph / 50-60Hz

INLET DIAMETER: 1 1/2" OD

VACUUM: 7.0" Hg.

PULSE DURATION: 500 milliseconds

TOTAL PULSES: 1-499 (adjustable, dump time dependant)

AIR SERVICE: 80 PSI required

FLOW RATE GRAPH

Note: flow rates and capacities are based on free-flowing pellets weighing 38 pounds per cubic foot, with a vertical rise of 12 feet and on 90° coupling. For conveying powders, or materials outside the above parameters, please consult the factory. It is recommended a sample of this material be submitted to our laboratory before recommendations can be made and accurate flow/rates established.

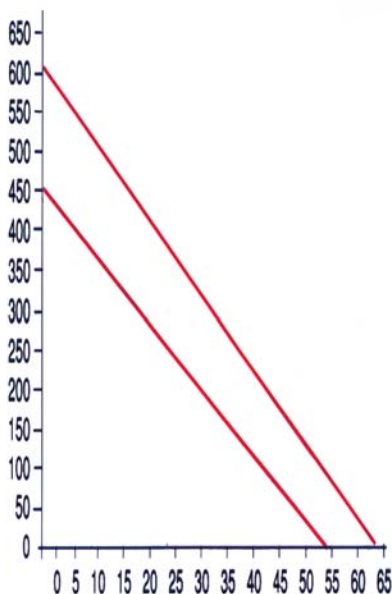

Expanded steel filter support extends filter life

Durable polyester filter traps fines

Tangential inlet deflector shield minimizes material degradation

Heavy duty cast aluminum full flow dump throat speeds operation

Reliable, mercury 'low-level' switch located on discharge gate provides 'Loader On' signal to controller.



TVL-5 shown

Accumulator tank assures an increased volume of compressed air for filter blowback.

Compressed air blowback after every loading cycle automatically provides complete, effective cleaning of filter.

Stainless steel band clamp with safety latch provides easy access with no tools. Gasket behind band clamp protects against loss of vacuum.

Heavy duty stainless steel construction

Custom molded neoprene gasket on dump throat assures tight seal and no loss of vacuum.

Aluminum discharge gate is counter balanced to automatically return to closed position as resin evacuates the vacuum chamber.

JIT Loader Option includes:

- Sight Glass Tube
- Photoeye Level Switch
- 3 Pole Twist - Lock Plug
- Aluminum Plate for Secure Mounting
- Adjustable Level Sensor

PRICE & PERFORMANCE... for the LONG TERM

525 East Stop 18 Road Greenwood, IN 46142 317-887-6352 fax: 317-881-1277 web site: www.Temptek.com email: sales@Temptek.com

Since product innovation and improvement is our constant goal, all features and specifications are subject to change without notice. ©2005 TEMPTTEK, INC. form # ADV-579 2/05

www.aoksupplies.com

TEMPTTEK

since 1989